



## MODEL #115V

Single Flavor Variegator / Revel Injector / Ripple Injector

### Description:

Inline, high volume, stainless steel, single flavor variegator.

### Products:

Ice cream, frozen yogurt, processed cheese, oatmeal, muffin mix or similar products that can be supplied continuously.

### Key Features:

- Unique easy-clean injector design
- High quality honed variegator tees
- Precisely formed tubes
- Wide variety of different injectors available
- Convertible to high pressure model #115V-HP
- Double o-ring rear seal disc; prevents leakage
- Same day repair service

### Line Size Options and Recommended Volumes:

- 2.5" (for 300 to 1200 gallons per hour finished product)
- 3.0" (for 1200 to 2100 gallons per hour finished product)
- 4.0" (for 2100 to 3000 gallons per hour finished product)

### Options Available:

- Conversion to high pressure model #115V-HP
- Additional injector

\*\*\*Drive needed to rotate variegator,  
see Variegator Drives for selection.





## MODEL #115V

### Features and Benefits

#### **Unique Easy-Clean Injector Design:**

- No hard to clean unsanitary dead-ends with our injectors
- You can see through and/or brush through all of our injector tubes
- All product contact surfaces easily cleaned and inspected

#### **High Quality Honed Variegator Tees:**

We only use the best quality tees built to our specifications.

- The internal diameter of our syrup tees are honed to assure a perfect fit
- Ferrules welded at a 90° angle on both ends keep patterns in line
- Perfect fit assures consistent patterns day in and day out

#### **Precisely Formed Tubes:**

Pre-formed tubes ensure consistent patterns, each time, every time.

#### **Wide Variety of Different Injectors Available:**

Over the years we have developed and built many custom variegator and injector nozzles. So if you don't find what you want, call. Chances are we've already done it!

- Multi-diameter injector available with tube sizes from 1/4" O.D. to 3/4" O.D.
- Custom injector available with 1 to 6 tubes

#### **Convertible to High Pressure Model #115V-HP:**

Designed for viscous products or extreme high volume applications. A dual piston injector with u-cup seals is used along with a high temperature rear guide bushing.

- Contains pressure between two welded stainless steel pistons
- Relieves pressure and wear on split wear ring

#### **Same Day Repair Service:**

If you do have a problem with one of our variegators, send it back and we will repair it the same day.





**T.D. Sawvel Co. Inc.**

Providing Automated Packaging Solutions Since 1976

Notes:

## MODEL #115V

Specifications and Elevation Drawing

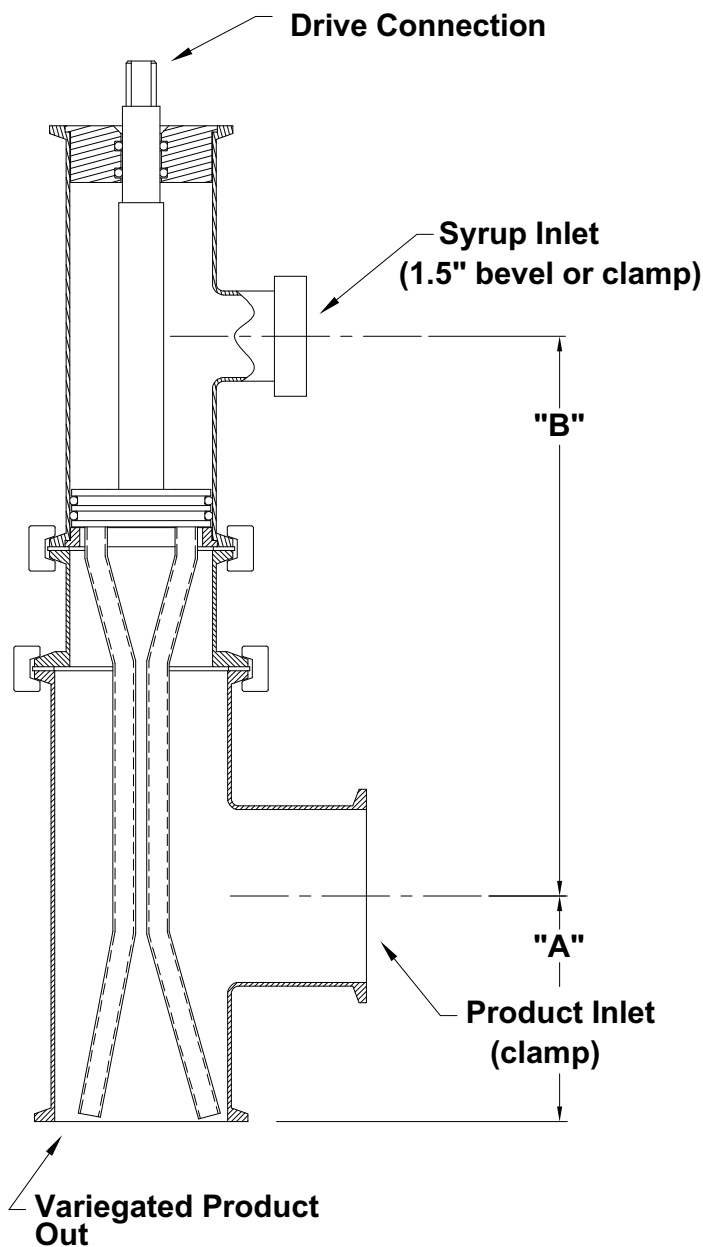

### **Model 115V - 2.5"**

"A" = 3.5" (8.89 cm)

"B" = 7.06" (17.93 cm)

Shipping Weight: 10 lbs (4.6 kg)

### **Model 115V - 3.0**

"A" = 3.75" (9.52 cm)

"B" = 9.31" (23.64 cm)

Shipping Weight: 13 lbs (5.9 kg)

### **Model 115V - 4.0**

"A" = 4.50" (11.43 cm)

"B" = 10.31" (26.20 cm)

Shipping Weight: 18 lbs (8.2 kg)