



**T.D. Sawvel Co. Inc.**

Providing Automated Packaging Solutions Since 1976

Notes:

## MODEL #108V

Single Flavor Variegator / Revel Injector / Ripple Injector

### Description:

Inline, stainless steel, single flavor variegator featuring 2 leg, plastic injector nozzle.

### Products:

Ice cream, frozen yogurt, processed cheese, oatmeal, muffin mix or similar products that can be supplied continuously.

### Key Features:

- Unique easy-clean injector design
- High quality variegator tees
- Interchangeable plastic injector nozzles
- Double o-ring rear seal disc; prevents leakage
- Large selection of air and electric drives
- Same day repair service
- Affordably priced

### Line Size Options and Recommended Volumes:

- 2.5" (for 300 to 900 gallons per hour finished product)
- 3.0" (for 900 to 1500 gallons per hour finished product)

### Options Available:

- 3 leg plastic nozzle
- 4 leg plastic nozzle
- 1 leg plastic marshmallow nozzle

\*\*\*Drive needed to rotate variegator, see Variegator Drives for selection.



[tdsawvel.com](http://tdsawvel.com)

Toll Free: 877.488.1816 • Phone 763.479.4322 • Fax 763.479.3517 • 5775 Highway 12 West • Maple Plain, MN 55359 U.S.A



**T.D. Sawvel Co. Inc.**

Providing Automated Packaging Solutions Since 1976

Notes:

## **MODEL #108V**

Features and Benefits

### **Unique Easy-Clean Injector Design:**

- No hard to clean unsanitary dead-ends with our injectors
- You can see through and/or brush through all of our injector tubes
- All product contact surfaces easily cleaned and inspected

### **High Quality Variegator Tees:**

We use only the best quality tees built to our specifications.

- Ferrules welded at a 90° angle on both ends keep patterns in line
- Perfect fit assures consistent patterns day in and day out

### **Interchangeable Plastic Injector Nozzles:**

These high quality nozzles are built to our specifications.

- High quality sanitary construction
- Extensive research and testing guarantee distinctive patterns
- Available in one, two, three and four leg designs

### **Same Day Repair Service:**

If you do have a problem with one of our variegators, send it back and we will repair it the same day.

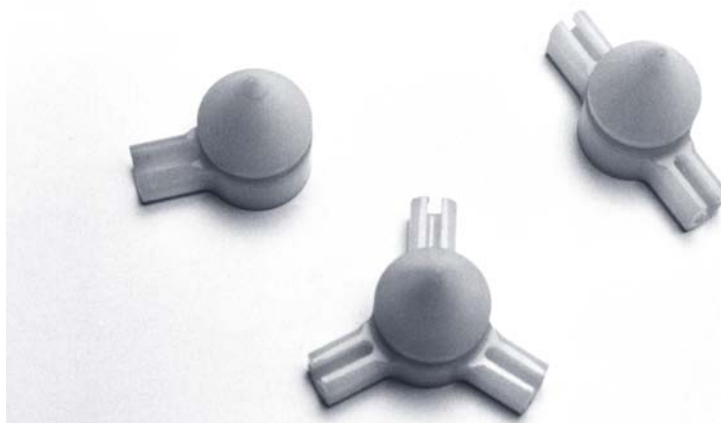
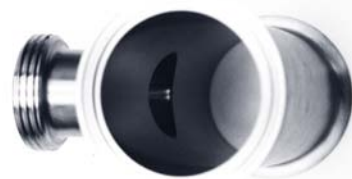

[tdsawvel.com](http://tdsawvel.com)

Toll Free: 877.488.1816 • Phone 763.479.4322 • Fax 763.479.3517 • 5775 Highway 12 West • Maple Plain, MN 55359 U.S.A



**T.D. Sawvel Co. Inc.**

Providing Automated Packaging Solutions Since 1976

Notes:

## MODEL #108V

Specifications and Elevation Drawing

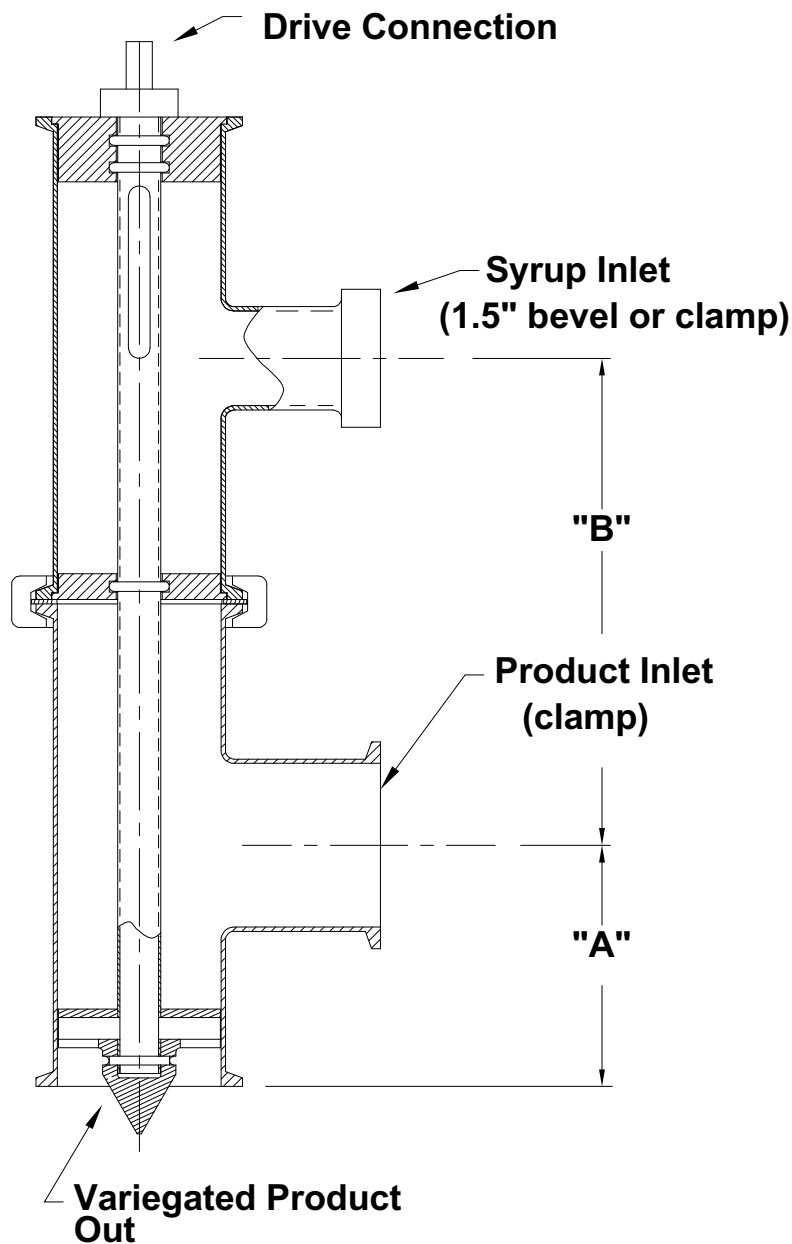

### **Model 108V - 2.5**

"A" = 3.5" (8.89 cm)

"B" = 7.06" (17.93 cm)

Shipping Weight: 8 lbs (3.6 kg)

### **Model 108V - 3.0**

"A" = 3.75" (9.52 cm)

"B" = 9.31" (23.64 cm)

Shipping Weight: 11 lbs (5 kg)