



**T.D. Sawvel Co. Inc.**

Providing Automated Packaging Solutions Since 1976

Notes:

## **MODEL #107B-M**

Inline Marbling Blender / Inline Mixer / Paddle Blender

### **Description:**

Inline, stainless steel marbling blender featuring 4-blade mix paddle. Used for multi-color products; creates distinctive marble pattern while maintaining identity.

### **Products:**

Ice cream, frozen yogurt, processed cheese, oatmeal, muffin mix or similar products that can be supplied continuously.

### **Key Features:**

- Interchangeable with our variegator
- Unique 4-blade mix paddle
- High quality fittings
- High temperature rear guide bushing with u-cup seal; prevents leakage
- 304 stainless steel construction
- Large selection of air and electric drives
- Same day repair service
- Affordably priced

### **Line Size Options and Recommended Volumes:**

- 2.5" (for 300 to 1200 gallons per hour finished product)
- 3.0" (for 1200 to 1500 gallons per hour finished product)

### **Options Available:**

- Additional mix paddles



\*\*\*Drive needed for blenders, see Blender Drives for selection.

[tdsawvel.com](http://tdsawvel.com)

Toll Free: 877.488.1816 • Phone 763.479.4322 • Fax 763.479.3517 • 5775 Highway 12 West • Maple Plain, MN 55359 U.S.A



**T.D. Sawvel Co. Inc.**

Providing Automated Packaging Solutions Since 1976

Notes:

## **MODEL #107B-M**

Features and Benefits

### **Interchangeable with Our Variegators:**

This unit will fit in place of one of our variegators.

- Quick change over from variegated to marbled products

### **Unique 4-Blade Mix Paddle:**

- Pushes product downstream when run clockwise; pushes upstream when drive is reversed
- All welds are 100% ground and polished
- All product contact surfaces easily cleaned and inspected

### **High Quality Fittings:**

We use only the best quality tees and fittings built to our specifications.

- Ferrules welded at a 90° angle on both ends
- Perfect fit ensures consistent mixing day in and day out

### **Same Day Repair Service:**

If you do have a problem with one of our variegators, send it back and we will repair it the same day.





Notes:

## MODEL #107B-M

Specifications and Elevation Drawing

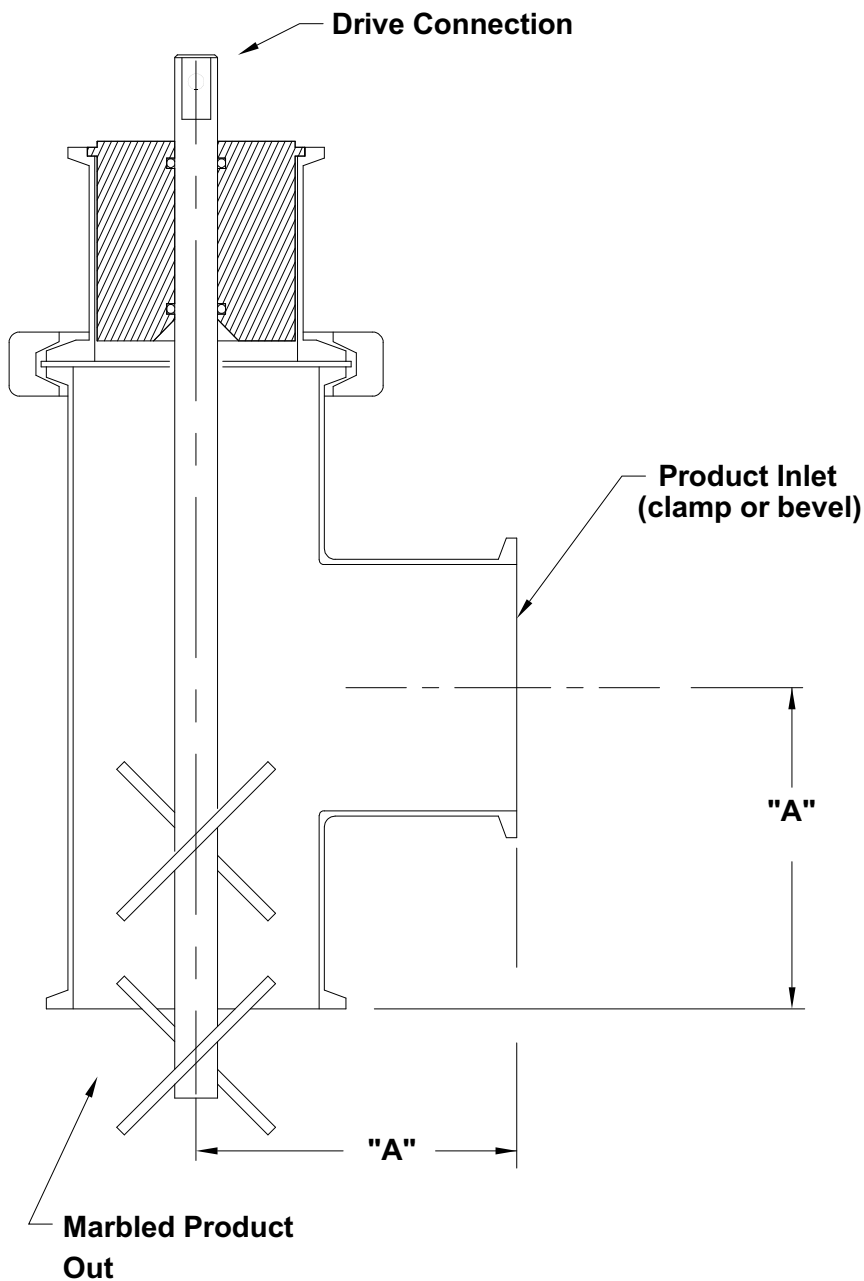

### Model 107B-HD - 2.5"

"A" = 3.5" (8.89 cm)

Shipping Weight: 8 lbs (3.6 kg)