



Notes:

MODEL #107B-HD

Inline Blender

Description:

Inline, stainless steel, heavy-duty blender, featuring 8-blade mix paddle and discharge end guide bushing.

Products:

Ice cream, frozen yogurt, processed cheese, oatmeal, muffin mix or similar products that can be supplied continuously.

Key Features

- Unique 8-blade mix paddle
- Guide bushing at discharge end
- High quality mix housing
- 304 Stainless steel construction
- High temperature rear guide bushing with u-cup seal, prevents leakage
- Large selection of air and washdown-rated electric drives
- Affordably priced
- Same day repair service

Line Size Options and Recommended Volumes:

- 2.5" (for 300 to 1200 gallons per hour finished product)
- 3.0" (for 1200 to 2100 gallons per hour finished product)
- 4.0" (for 2100 to 3000 gallons per hour finished product) *

* Drive included on 4.0" blender

Options Available:

- Additional mix paddles

*** Drive needed for blenders, see Blender Drives for selection.



*Model Shown
107B-HD Blender*



Notes:

MODEL #107B-HD

Features and Benefits

Unique 8-Blade Mix Paddle:

- Pushes product downstream when run clock wise, pushes upstream when drive is reversed
- All welds are 100% ground and polished
- All product contact surfaces easily cleaned and inspected

High Quality Extended Tee Housing:

We use only the best quality housings built to our specifications.

- Ferrules welded at a 90.0 degree angle on both ends
- Perfect fit ensures consistent mixing day in and day out

Guide Bushing at Discharge End:

The mix paddle is supported at both ends to assure proper alignment.

- Provides more consistent mixing
- Impossible for mix blades to contact blender housing

Same Day Repair Service:

If you do have a problem with one of our variegators, send it back and we will repair it the same day.

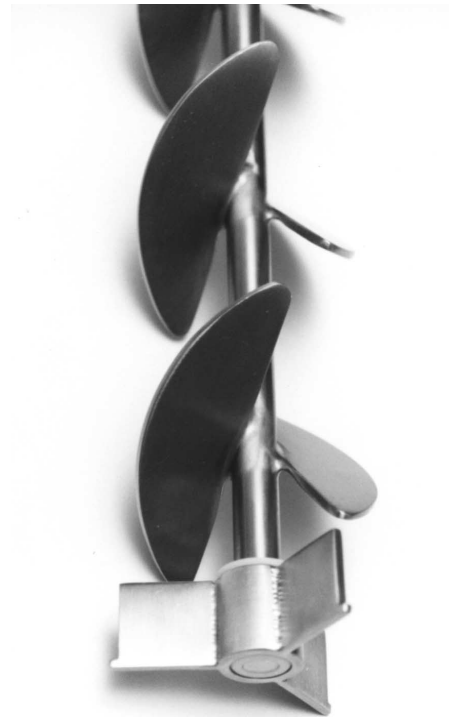



Notes:

MODEL #107B-M

Specifications and Elevation Drawing

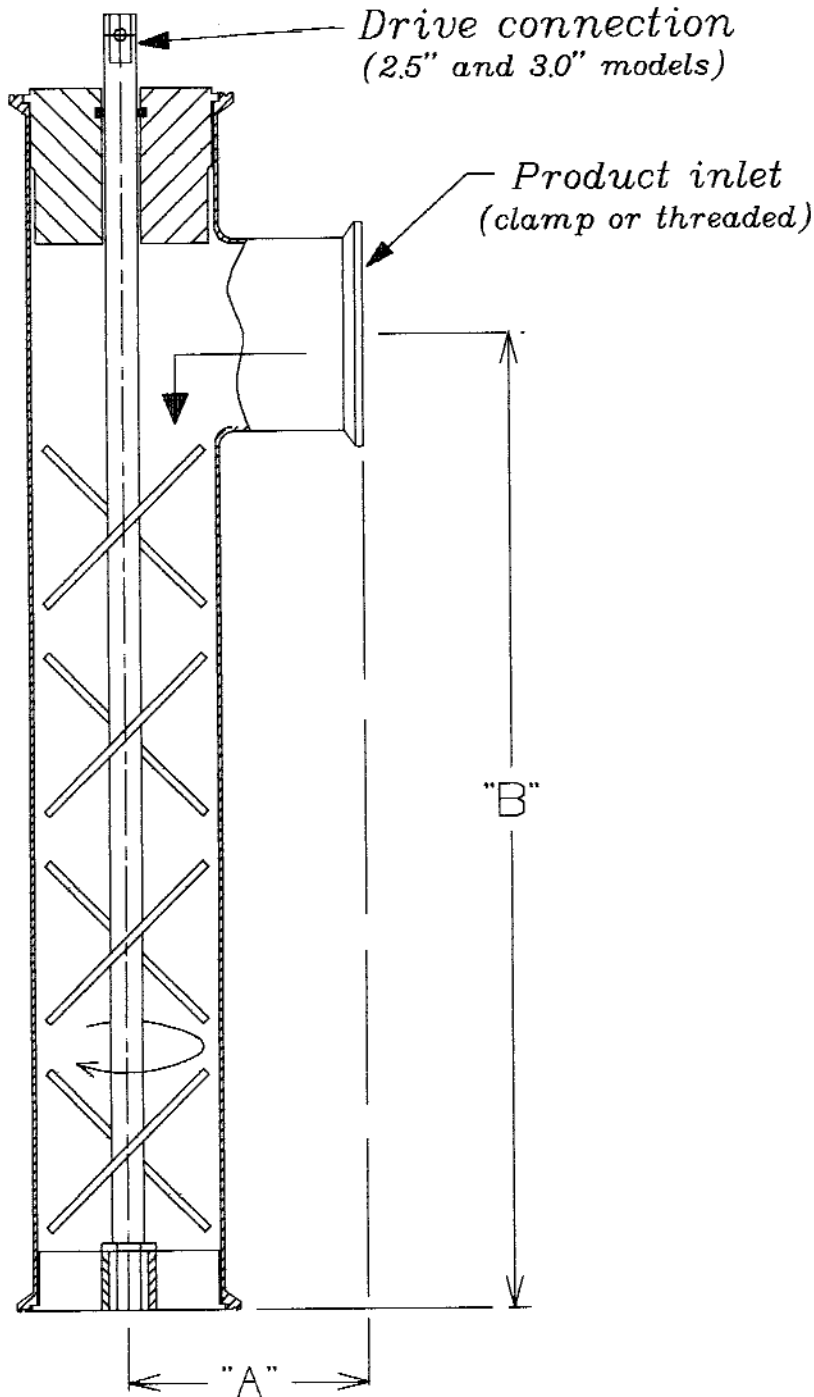

Model 107B-HD-2.5"

"A" = 3.5" [8.89 cm]

"B" = 13.50" [34.29 cm]

SHIPPING WEIGHT:

13 LBS [5.9 KG]

Model 107B-HD-3.0"

"A" = 3.75" [9.52 cm]

"B" = 15.25" [38.74 cm]

SHIPPING WEIGHT:

16 LBS [7.3 KG]

Model 107B-HD-4.0"

With 1/2 hp AC drive
and I-Line fittings

"A" = 4.50" [11.43 cm]

"B" = 24.00" [60.96 cm]

SHIPPING WEIGHT:

50 LBS [22.7 KG]