



## **MODEL #133D**

Auger Denester / Cup Denester / Container Feeder / Container De-stacker

### **Description:**

Automatic auger denester designed to separate nested packaging.

### **Key Features:**

- Containers drop vertically from bottom of augers
- Hopper capacity approximately 60 containers
- Wide range of custom tooling available
- Easy integration with other equipment
- Pneumatic operation
- Custom mountings can be designed to fit your application
- Speeds to 80 cpm
- 304 stainless steel and plastic construction

### **Containers:**

- Round, rectangular, square and square-round
- 4 ounce through 3 gallon
- 2.5" through 9" diameter

### **Container Types:**

- Molded or vacuum formed cups, pails and trays in a wide variety of shapes and sizes

### **Options Available:**

- Tooling for additional container sizes





**T.D. Sawvel Co. Inc.**

Providing Automated Packaging Solutions Since 1976

Notes:

## MODEL #133D

Specifications and Elevation Drawing

### Air Requirements:

4 cfm @ 80 psi

### Electrical Requirements:

110V AC, 60 HZ, 1Phase, 5 amp

### Shipping Weight:

40 lbs.

### Width:

1' 11" (59 cm)

### Length:

2' 5 1/2" (74.3 cm)

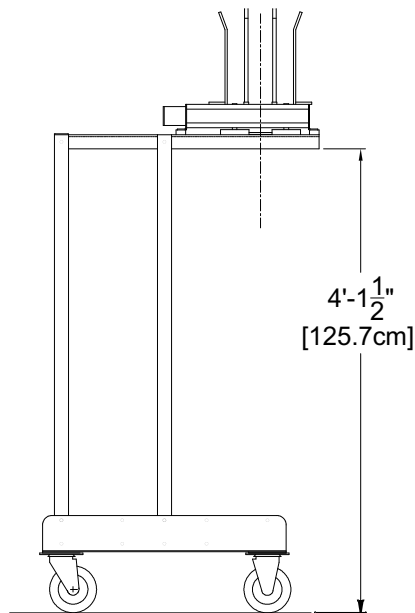
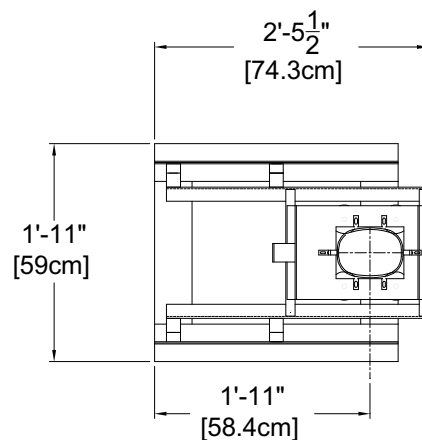

[tdsawvel.com](http://tdsawvel.com)

Toll Free: 877.488.1816 • Phone 763.479.4322 • Fax 763.479.3517 • 5775 Highway 12 West • Maple Plain, MN 55359 U.S.A